

- Unit used to fix and rotate control panels for machine tools, etc.
- A single **DKSF** unit can be used either as a post type with the control panel mounted on the top or as a suspension type with the panel mounted on the bottom.
- The flange mounting holes on the rotating part and main body enable mounting from either top or bottom. Use along with the device/equipment on which the panel is to be mounted.
- Control panel wiring can be passed through from the **DKSF** central hole.
- Tightening the clamp lever will lock the control panel rotation.
- Tighten the 3 operating torque adjusting screws equally to adjust the operating torque.
- Mount the included stopper bolts at an arbitrary position on the **DKSF** bottom to restrict the locating disk rotation angle and set the control panel rotation angle. The rotation angle can be set within a range of 45° to 360°. For details, refer to the Rotation Angle Setting Table.

Related Products

DKSP stand pipes are available for height adjustment, used in combination with **DKSF**.



Material/Finish



	DKSF
Main Body	Cast Iron Cathodic Electrodeposition Coating (Black)
Rotating part	Cast Iron Cathodic Electrodeposition Coating (Black)
Locating Disk	Cast Iron Cathodic Electrodeposition Coating (Black)
Clamp Lever	Zinc Die Cast Electrostatic Coating (Matte Black)
Operating Torque Adjusting Screw	Steel Ferrosferic Oxide Film (Black), Nylon Patch (Nylon 11)
Stopper Bolt M5 x 8	Steel Ferrosferic Oxide Film (Black)

Part Number	D	D ₁	d	P	Max. Load Weight (kg)	Allowable Moment *1 (N·m)	Retention Torque *2 (N·m)	Mass (g)
DKSF-115-45	115	80	45	95	100	200	30	2580
DKSF-130-60	130	95	60	110	100	315	30	3130

*1: Allowable value for the eccentric load received from the control panel mounted on the rotating part or main body.
 *2: Retention torque is the reference maximum retention torque generated when tightening the clamp lever at the maximum clamping force (3.9kN) with no control panel mounted. The retention torque fluctuates in accordance with the tightening strength.

- Two stopper bolts are provided.

Part Number Specification

DKSF-115-45



Precautions for Use

- When rotating the control panel, move it slowly so as not to apply impact to the stopper bolts. The stopper bolts may break under large impact, making it impossible to restrict the control panel rotation angle.
- When rotating the control panel, check that no one is in its vicinity. Injuries may occur if the control panel makes contact with persons nearby.
- When not using the stopper bolts, the control panel rotation will be unrestricted. Be careful not to twist the wiring.
- Do not rotate screws other than the operating torque adjusting screws and stopper bolts. **DKSF** may be damaged if screws are rotated.
- When installing the control panel to be used, calculate the moment load it generates. Installation is possible if the moment load generated from the control panel does not exceed the allowable moment value.
- Calculation Example of Moment Load Generated from Control Panel <Conditions>
 Operating panel mass : 30kg
 Horizontal distance from swivel unit rotation axis to control panel center of gravity : 112mm

Control panel load
 = Control panel mass x gravity acceleration
 = 30kg x 9.8
 = 294N

Moment load generated from control panel
 = Horizontal distance from swivel unit rotation axis to control panel center of gravity x control panel load
 = 0.112m x 294N
 = 32.9N·m

For example, the allowable moment for **DKSF-115-45** is 200 N·m, As 32.9N·m < 200N·m, control panel installation is possible

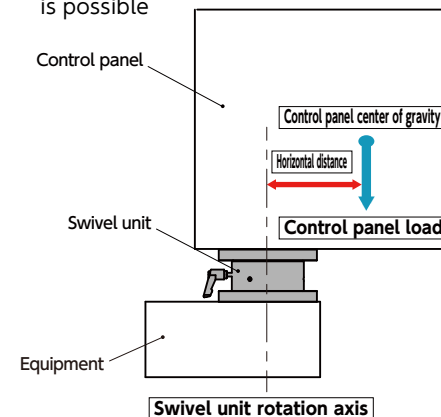

- Durability Test Data
 < **DKSF-115-45** Test Conditions >
 Moment load generated from control panel : 200 N·m
 Operation of 1 cycle : Rotate the control panel about 60° and return it to the original position
 Number of test cycles : 21,000

<Operating Torque Change*1>

Before test : 5.1 N·m
 After test : 13.0 N·m

< **DKSF-130-60** Test Conditions >

Moment load generated from control panel : 315 N·m
 Operation of 1 cycle : Rotate the control panel about 60° and return it to the original position
 Number of test cycles : 21,000

<Operating Torque Change*1>

Before test : 4.2 N·m
 After test : 25.9 N·m

*1: Operating torque is the value measured with the operating torque adjusting screw free.

Operating Torque Adjusting Method

- Repeated use will lead to wear on the contact parts, reducing the operating torque. Adjust the operating torque periodically.

1 Loosen the clamp lever.

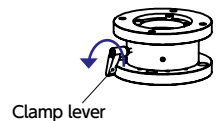

2 Insert 3 operating torque adjusting screws into the **DKSF** interior until they make light contact.

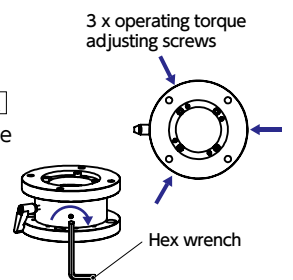

3 To increase the operating torque, adjust by tightening the 3 operating torque adjusting screws equally.

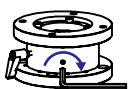

● Mounting (Application: Post Type)

① When restricting control panel rotation angle*1

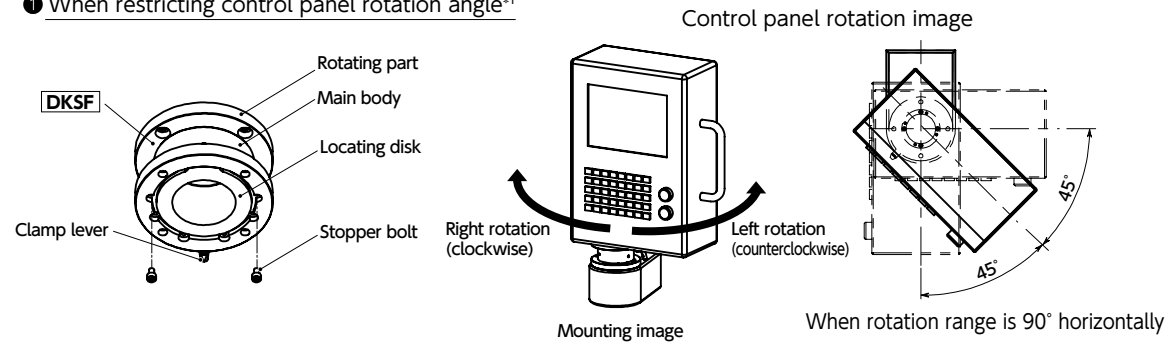

The control panel rotation angle can be restricted through a combination of the mounting position of the provided stopper bolts and the position of the locating disk.

For the rotation angle setting, refer to the Rotation Angle Setting Table. With the clamp lever loosened, rotate the rotating part or the main body and mount the stopper bolts. (Reference tightening torque: 2N · m)
After setting the rotation angle, tighten the clamp lever in accordance with the reference position in the table and lock the rotation.

*1: This process is not required when not restricting the control panel rotation angle.

② When fixing DKSF from the top

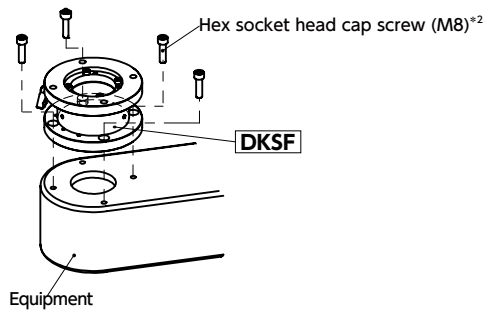

With the DKSF locating disk facing downward, fix DKSF to the equipment with 4 hex socket head cap screws (M8)*2.

②' When fixing DKSF from the bottom

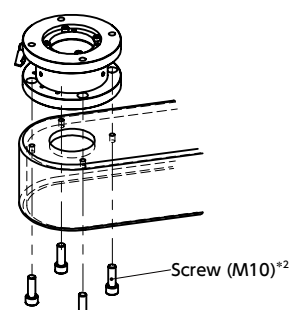

With the DKSF locating disk facing downward, fix DKSF with 4 screws (M10)*2.

③ When fixing the control panel from the top

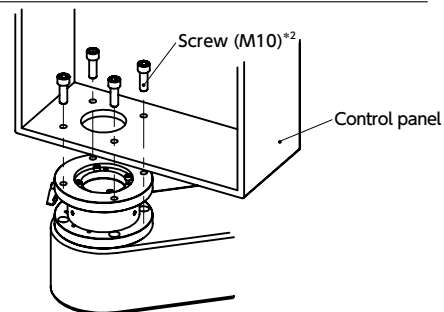

Fix the control panel with 4 screws (M10)*2.

③' When fixing the control panel from the bottom

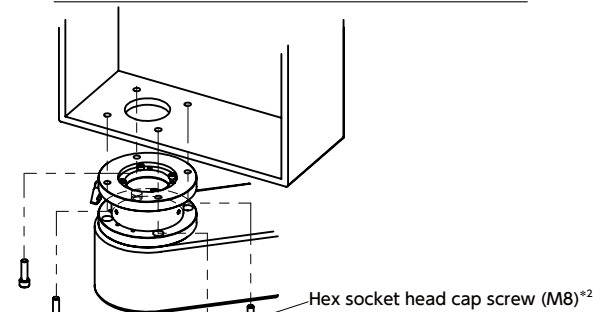

Fix the control panel with 4 hex socket head cap screws (M8)*2.

*2: Screws are not supplied.

● Mounting (Application: Suspension Type)

① When restricting control panel rotation angle*1

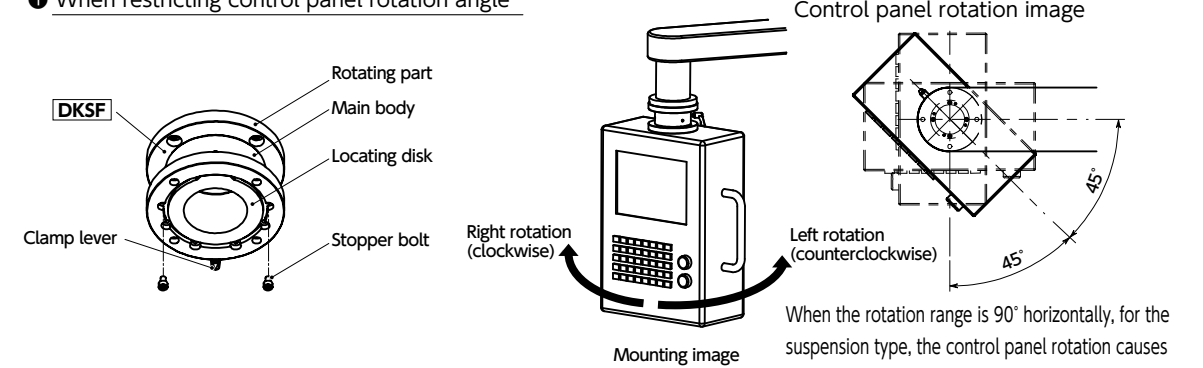

The control panel rotation angle can be restricted through a combination of the mounting position of the provided stopper bolts and the position of the locating disk.

For the rotation angle setting, refer to the Rotation Angle Setting Table. With the clamp lever loosened, rotate the rotating part or the main body and mount the stopper bolts. (Reference tightening torque: 2N · m)

After setting the rotation angle, tighten the clamp lever in accordance with the reference position in the table and lock the rotation.

*1: This process is not required when not restricting the control panel rotation angle.

② When fixing DKSF from the top

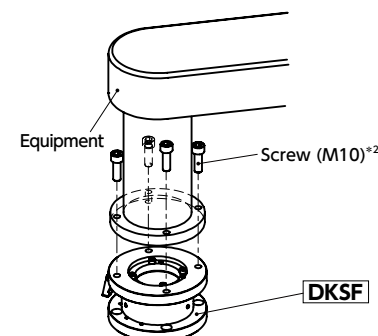

With the DKSF locating disk facing downward, fix DKSF to the equipment with 4 screws (M10)*2.

②' When fixing DKSF from the bottom

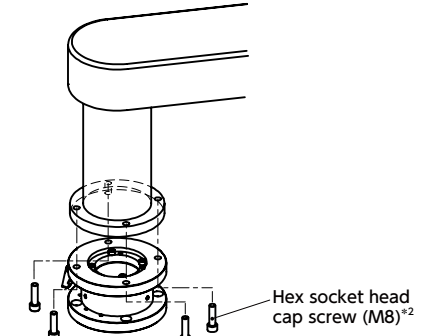

With the DKSF locating disk facing downward, fix DKSF to the equipment with 4 hex socket head cap screws (M8)*2.

③ When fixing the control panel from the top

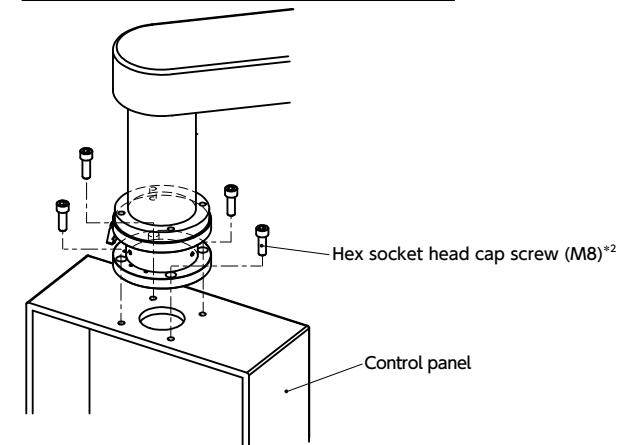

Fix the control panel with 4 hex socket head cap screws (M8)*2.

③' When fixing the control panel from the bottom

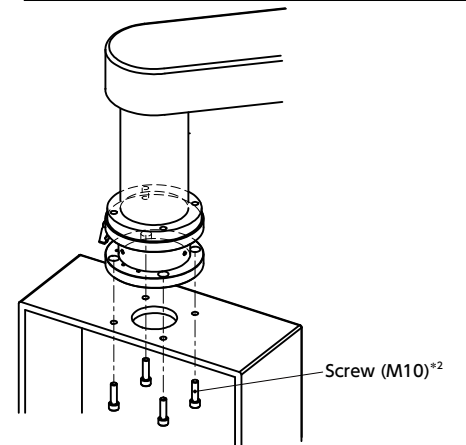

Fix the control panel with 4 screws (M10)*2.

*2: Screws are not supplied.